



Mobility Products 2016

Sakskøbingvej 6
DK-7400 Herning
Tel +45 5070 9215
info@develtex.dk



LIFT BBI

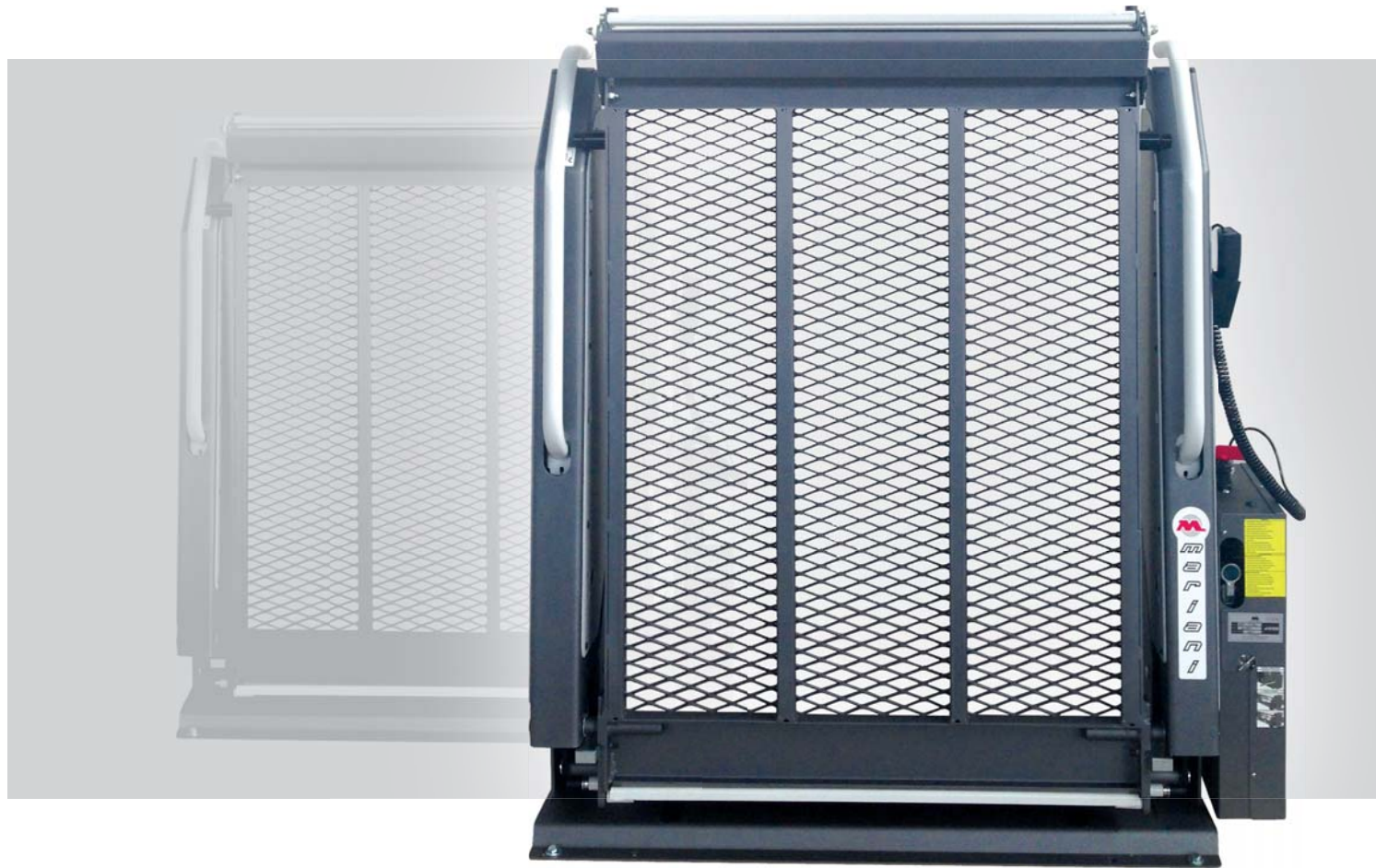

115/130/140



TECHNICAL FEATURES

MAXIMUM CAPACITY	360 Kg
WEIGHT	120 / 140 Kg
POWER	12 V - 24 V
MAX PRESSURE	140 Bar
LIFTING HEIGHT	920 mm.
SPEED UP (FULL LOAD)	5 M/MIN
SPEED DOWN (FULL LOAD)	4 M/MIN

SAFETY DEVICES

- Switch to detach battery with key.
- Manual operation in case of emergency.
- Automatic safety ramp to stop the wheelchair
- Pressure switch to prevent stowing when loaded.
- Anti-slip platform.

The double arm lift BBI, with one piece antislip platform, is completely automatic and has been designed and made to adapt medium/large sized commercial vehicles to be used for person transportation.

Left or right side mounted pumpstation can be chosen.

VEHICLE EXAMPLES:

Fiat Scudo, Fiat Ducato, Ford Transit, Iveco Daily, Opel Movano, Renault Traffic, Volkswagen Crafter Kombi.

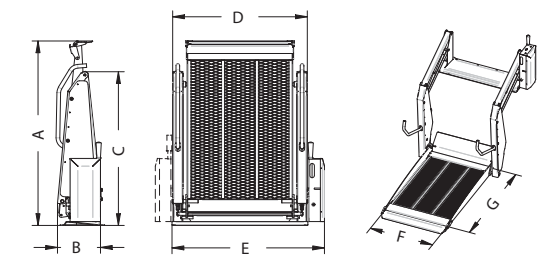
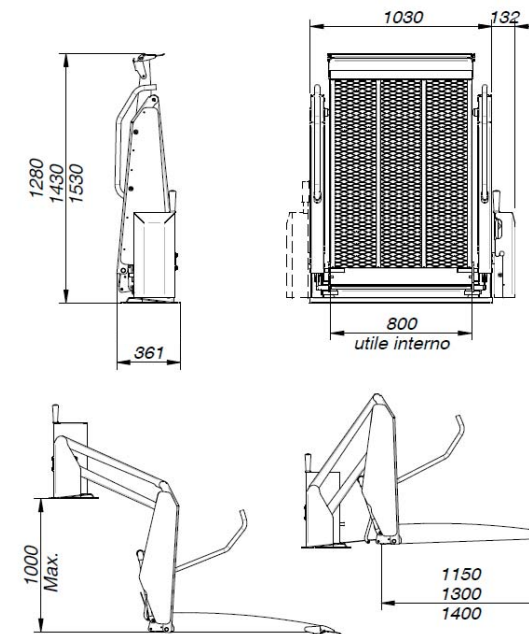

LIFT BBI	A	B	C	D	E	F	G
115.80	1280	361	1180	1030	1162	800	1150
130.80	1430	361	1180	1030	1162	800	1300
140.80	1530	361	1180	1030	1162	800	1400
140.90	1530	361	1180	1130	1262	900	1400

ORDERING KEY:

Example.

Model	Size	Pump side
2141	11580	L



LIFT BBO



115.73

TECHNICAL FEATURES

MAXIMUM CAPACITY	320 Kg
WEIGHT	110 Kg
POWER	12 V - 24 V
MAX PRESSURE	140 Bar
LIFTING HEIGHT	920 mm.
SPEED UP (FULL LOAD)	5 M/MIN
SPEED DOWN (FULL LOAD)	4 M/MIN

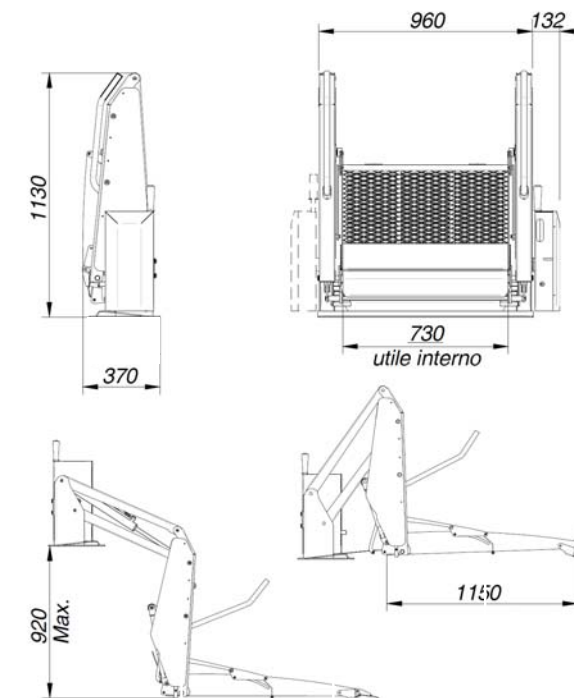

SAFETY DEVICES

- Switch to detach battery with key.
- Manual operation in case of emergency.
- Automatic safety ramp to stop the wheelchair.
- Pressure switch to prevent stowing when loaded.
- Anti-slip platform.

The automatic lift model BBO 115.73 has reduced dimensions and weight and has been conceived for small vehicles to transport persons.

Left or right side mounted pumpstation can be chosen.

VEHICLE EXAMPLES:
Citroen Jumpy, Fiat Doblo XL, Fiat Scudo, Ford Tourneo Custom, Mercedes Vito kombi, Peugeot Expert , Renault Trafic, Volkswagen California, Volkswagen Trasporter.

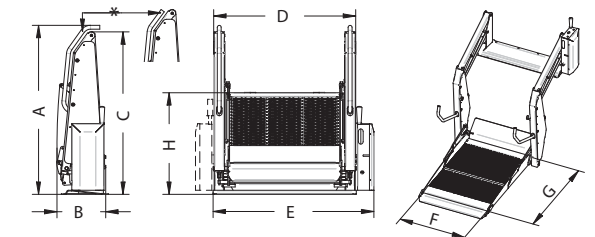

LIFT BBO	A	B	C	D	E	F	G
115.73	*1130	370	*1130	960	1100	730	1150

ORDERING KEY:

Example.
Model Size Pump side
2143 11573 L





LIFT BBO



115/125/140.80-90

TECHNICAL FEATURES

MAXIMUM CAPACITY	360 Kg
WEIGHT	135 -140 Kg
POWER	12 V - 24 V
SPEED UP (FULL LOAD)	5 M/MIN
SPEED DOWN (FULL LOAD)	4 M/MIN

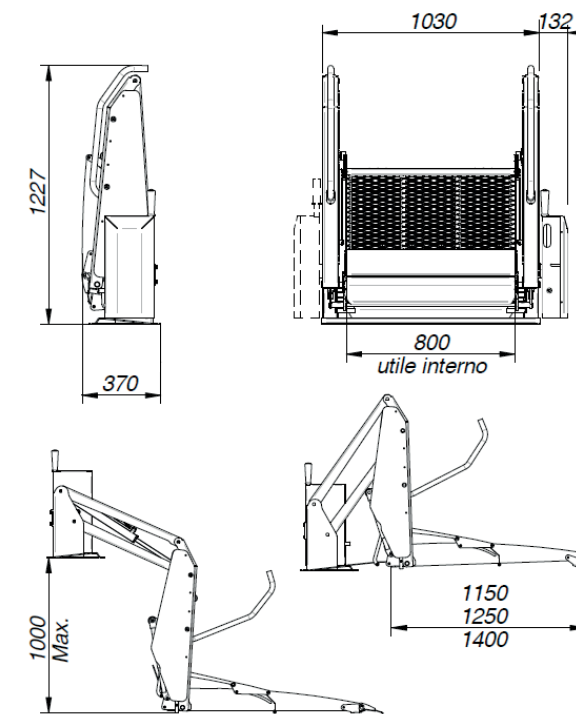

SAFETY DEVICES

- Switch to detach battery with key.
- Manual operation in case of emergency.
- Automatic safety ramp to stop the wheelchair.
- Pressure switch to prevent stowing when loaded.
- Anti-slip platform.

The automatic double arm platforms have been conceived for medium-large vehicles.

Left or right side mounted pumpstation can be chosen.

VEHICLE EXAMPLES:

Citroen Jumper, Fiat Scudo, Fiat Ducato, Ford Transit, Iveco Daily, Mercedes Sprinter Kombi, Opel Vivaro, Opel Movano, Peugeot Expert Tepee, Renault Trafic, Renault Master, Volkswagen Caravelle, Volkswagen Multivan, Volkswagen Crafter Kombi

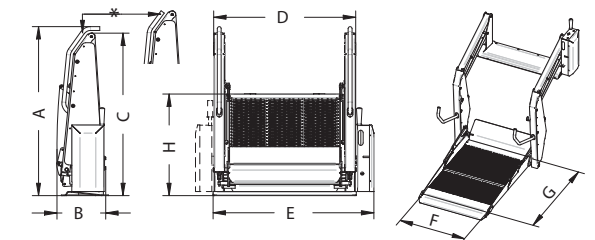

LIFT BBO	A	B	C	D	E	F	G
115.80	1227	370	1180	1030	1162	800	1150
125.80	1227	370	1180	1030	1162	800	1250
140.80	1227	370	1180	1030	1162	800	1400
140.90	1227	370	1180	1130	1262	900	1400

ORDERING KEY:

Example.

Model	Size	Pump side
2143	14080	L





LIFT BBV



103.75



TECHNICAL FEATURES

MAXIMUM CAPACITY	320 Kg
WEIGHT	110 Kg
POWER	12 V - 24 V
MAX PRESSURE	140 Bar
LIFTING HEIGHT	920 mm.
SPEED UP (FULL LOAD)	5 M/MIN
SPEED DOWN (FULL LOAD)	4 M/MIN

SAFETY DEVICES

- Switch to detach battery with key.
- Manual operation in case of emergency.
- Automatic safety ramp to stop the wheelchair.
- Pressure switch to prevent stowing when loaded.
- Anti-slip platform.

The double arm lift BBV 105.73 has the platform which opens vertically thus allowing a free space to go through and a good sight.

Left or right side mounted pumpstation can be chosen.

VEHICLE EXAMPLES:

Citroen Jumper, Fiat Scudo, Fiat Ducato, Ford Transit, Iveco Daily, Mercedes Sprinter Kombi, Opel Movano, Peugeot Expert Tepee, Renault Trafic, Renault Master, Volkswagen Caravelle - Multiva

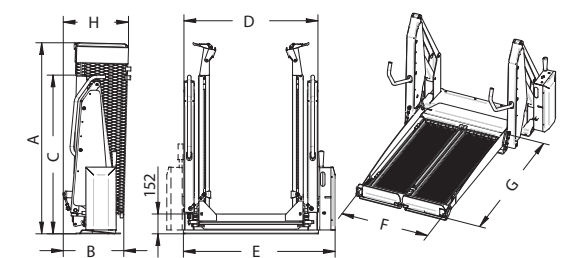
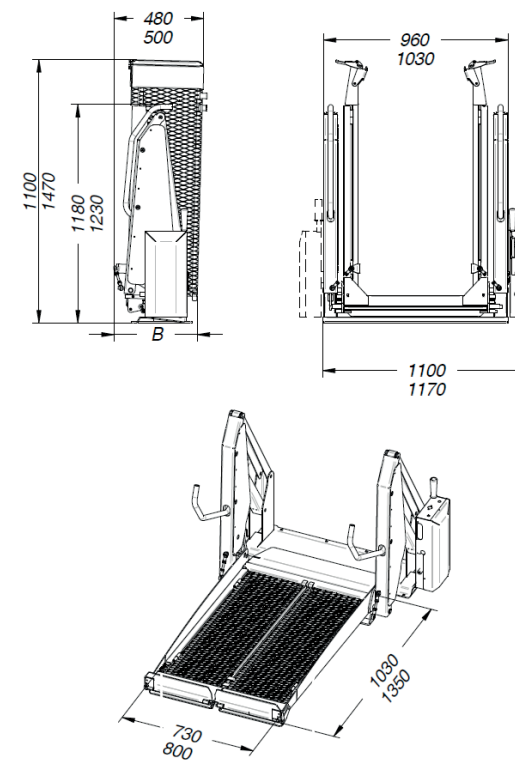

LIFT BBV	A	B	C	D	E	F	G
103.75	1100	425	1180	960	1100	730	1030
135.80	1470	460	1230	1030	1170	800	1350

ORDERING KEY:

Example.

Model	Size	Pump side
2142	10375	L



LIFT BBV



135.80

TECHNICAL FEATURES

MAXIMUM CAPACITY	360 Kg
WEIGHT	140 Kg
POWER	12 V - 24 V
MAX PRESSURE	140 Bar
LIFTING HEIGHT	920 mm.
SPEED UP (FULL LOAD)	5 M/MIN
SPEED DOWN (FULL LOAD)	4 M/MIN

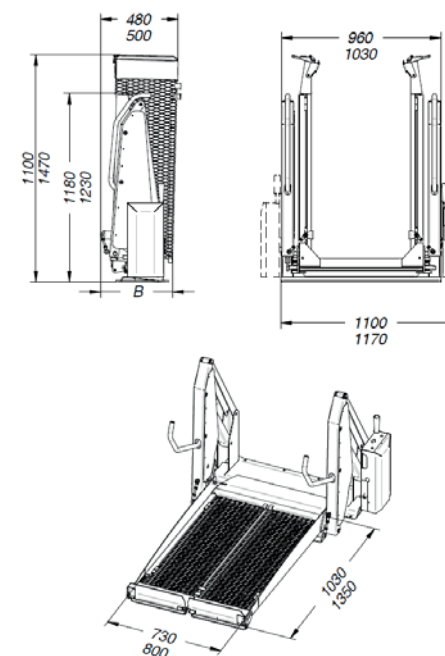

SAFETY DEVICES

- Switch to detach battery with key.
- Manual operation in case of emergency.
- Automatic safety ramp to stop the wheelchair.
- Pressure switch to prevent stowing when loaded.
- Anti-slip platform.

The double arm lift BBV 135.80 with antislip platform which opens vertically is completely automatic and has been conceived for medium-large sized vehicles that are used for person transportation.

Left or right side mounted pumpstation can be chosen.

VEHICLE EXAMPLES:

Ford Transit, Iveco Daily, Mercedes Sprinter Kombi, Opel Movano, Peugeot Expert Tepee, Renault Trafic, Renault Master, Volkswagen Caravelle, Volkswagen Crafter Kombi.

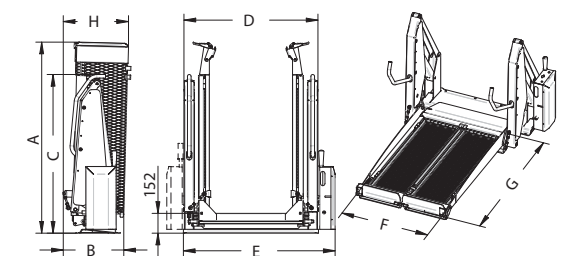

LIFT BBV	A	B	C	D	E	F	G
103.75	1100	425	1180	960	1100	730	1030
135.80	1470	460	1230	1030	1170	800	1350

ORDERING KEY:

Example.

Model	Size	Pump side
2142	13575	L





SINGLE ARM



250

TECHNICAL FEATURES

LOADING CAPACITY	250 Kg
WEIGHT	75 Kg
ELECTRICAL SYSTEM	12 V
OPENING SPEED	6 SEC
CLOSING SPEED	10 SEC

SAFETY DEVICES

The Single Arm lift SA 250 is particularly recommended to adapt small vehicles thanks to its reduced dimensions.

- Lifting platform entirely in aluminium with anti-slip surface.
- Semiautomatic operation.
- Cabled remote control.
- Emergency lever for manual operation.
- Safety stopping plates.
- Anti-overturn safety device.

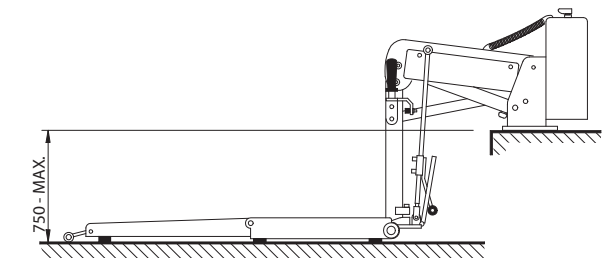
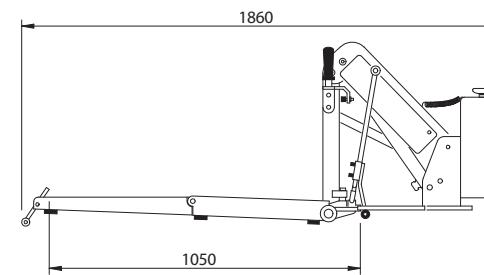
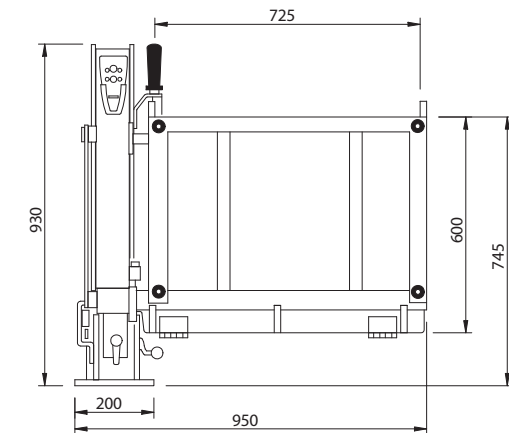
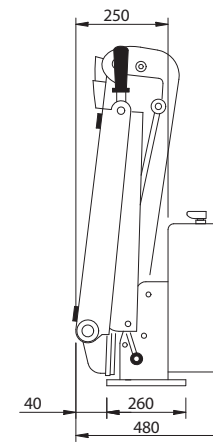



LIFT BBC

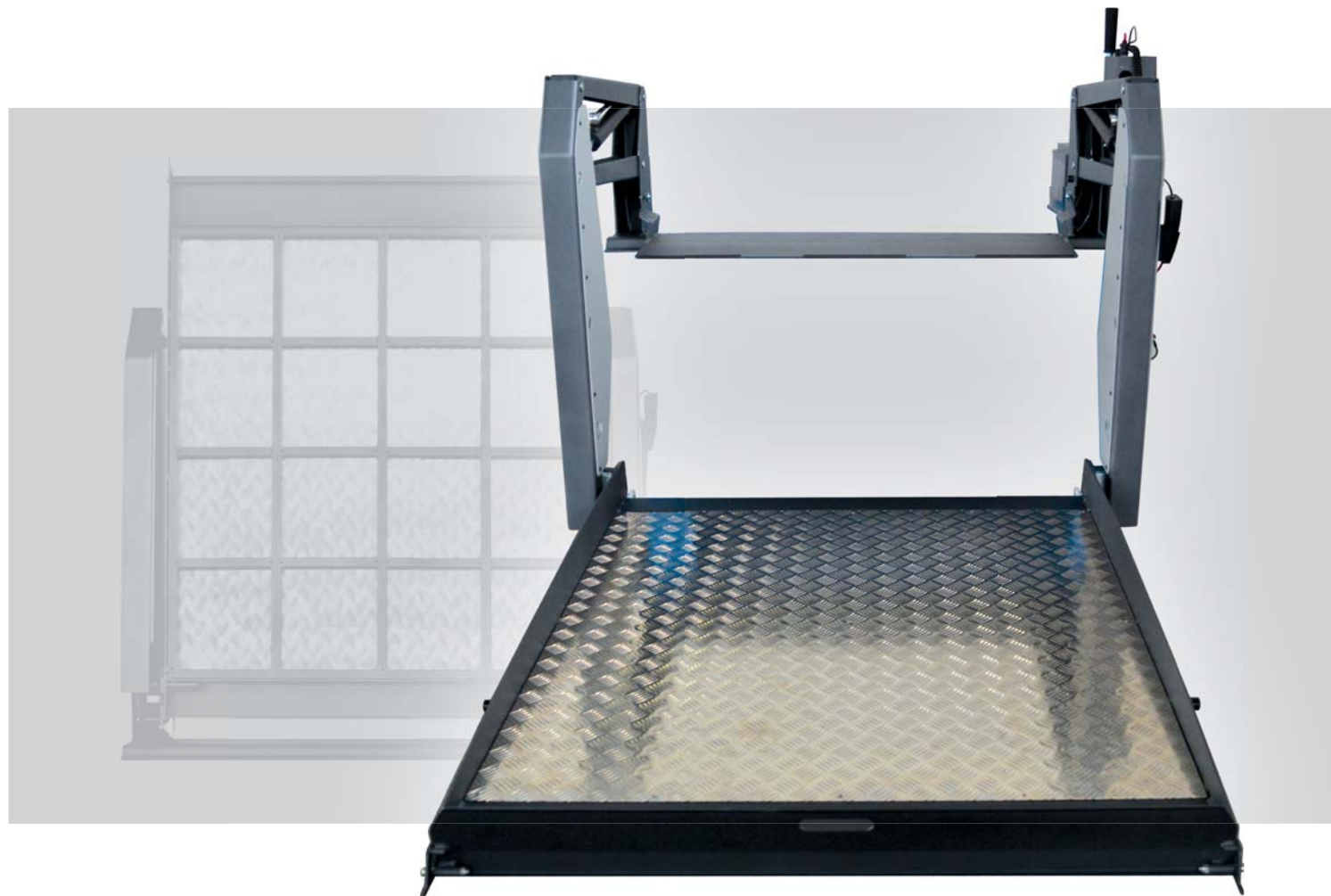

TECHNICAL FEATURES

MAXIMUM CAPACITY	500 Kg
WEIGHT	130/145 Kg
POWER	12 V - 24 V
MAX PRESSURE	140 Bar
LIFTING HEIGHT	920 mm.
SPEED UP (FULL LOAD)	5 M/MIN
SPEED DOWN (FULL LOAD)	4 M/MIN

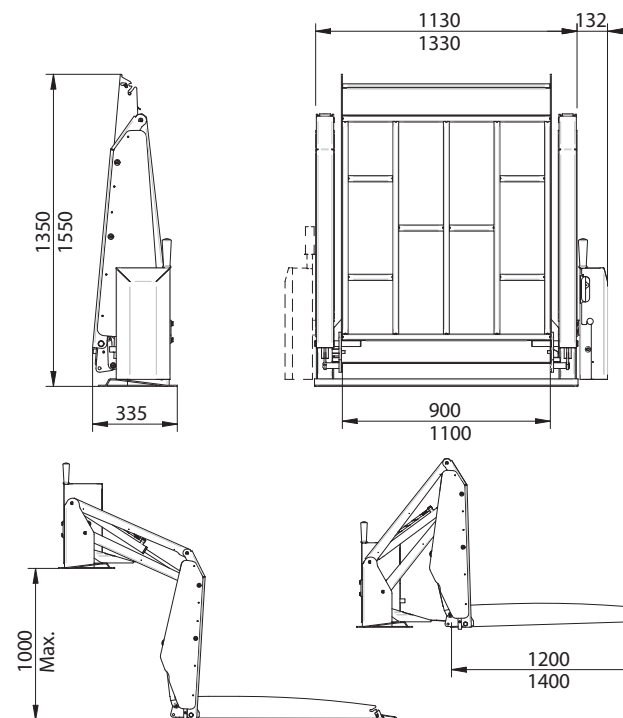

SAFETY DEVICES

- Switch to detach battery with key.
- Manual operation in case of emergency.
- Pressure switch to prevent stowing when loaded.

The BBC range platform lifts have been conceived to make the goods handling easy during the loading/unloading of commercial vehicles. This range of double arm lifts can solve many lifting problems especially on vehicles where conventional loading devices cannot be installed. The BBC lifts have a strong and stable platform in patterned aluminium. There are 2 sizes available.

Left or right side mounted pumpstation can be chosen.

VEHICLE EXAMPLES:

Fiat Ducato, Iveco Daily, Opel Vivaro , Opel Movano, Renault Master, Renault Traffic.

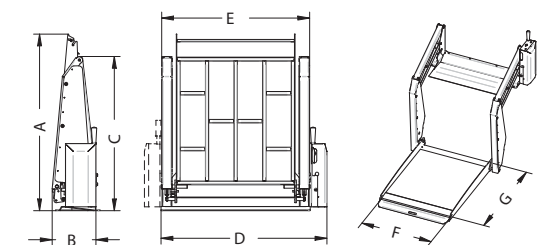

LIFT BBC	A	B	C	D	E	F	G
120.90	1350	335	1180	1270	1130	900	1200
140.110	1550	335	1180	1470	1330	1100	1400

ORDERING KEY:

Example.

Model	Size	Pump side
2144	140110	L





ELECTRICAL STEP

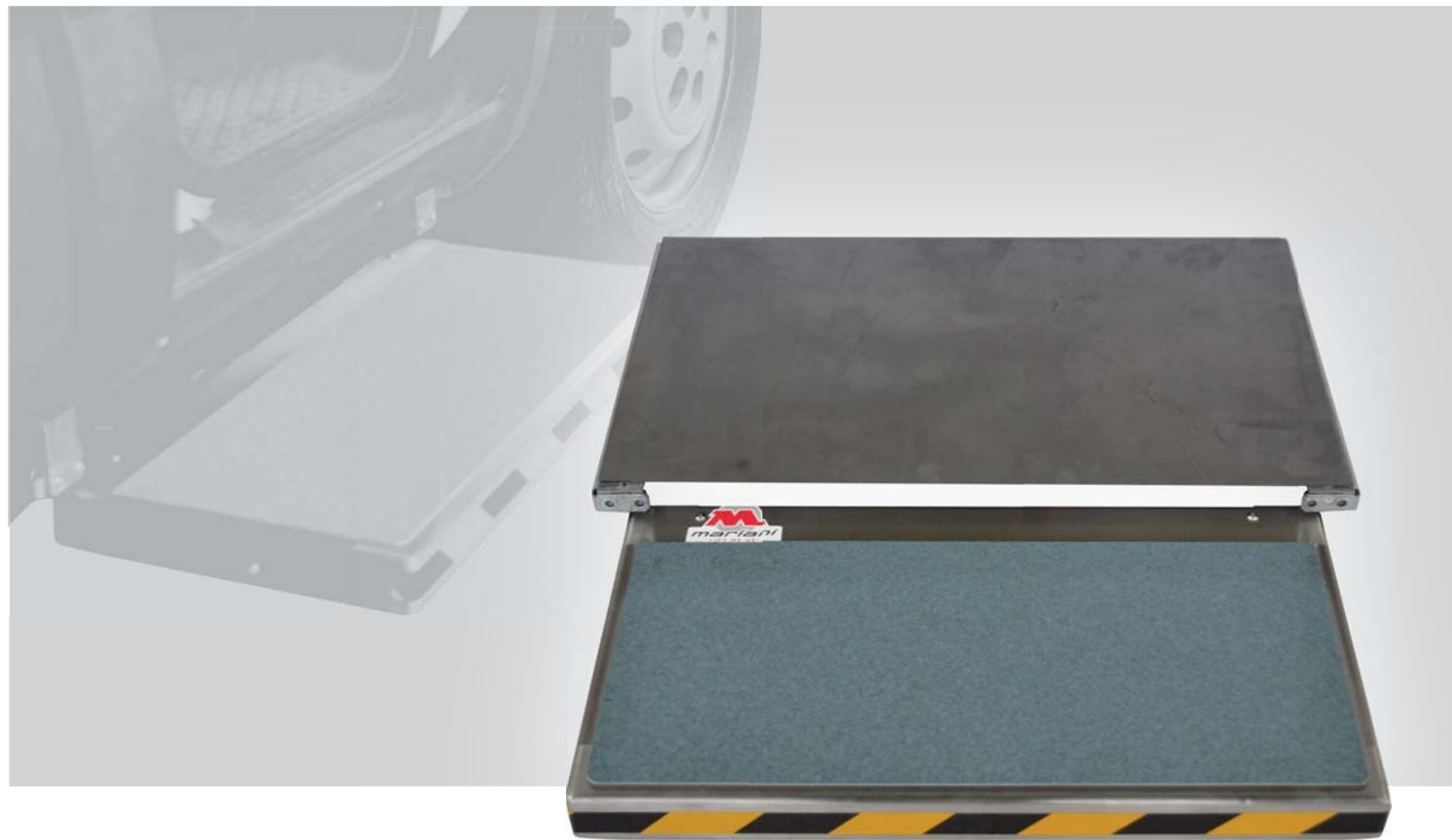

ESI 600

TECHNICAL FEATURES

LOADING CAPACITY	200 Kg
WEIGHT	15 Kg
ELECTRICAL SYSTEM	12 V
OPENING SPEED	3 SEC
CLOSING SPEED	3 SEC

SAFETY DEVICES

The ESI 600 electrical step helps in reducing the gap between the ground and the vehicle floor.

- Step inox.
- Zinc coated frame.
- Customized supports to adapt the steps to all types of vehicles can be available.
- Emergency lever for manual operation.
- Vehicle innerlight advising the step is out.
- Flashing light under the step when it is moving.
- Automatic stop if hitting obstacles

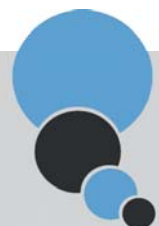
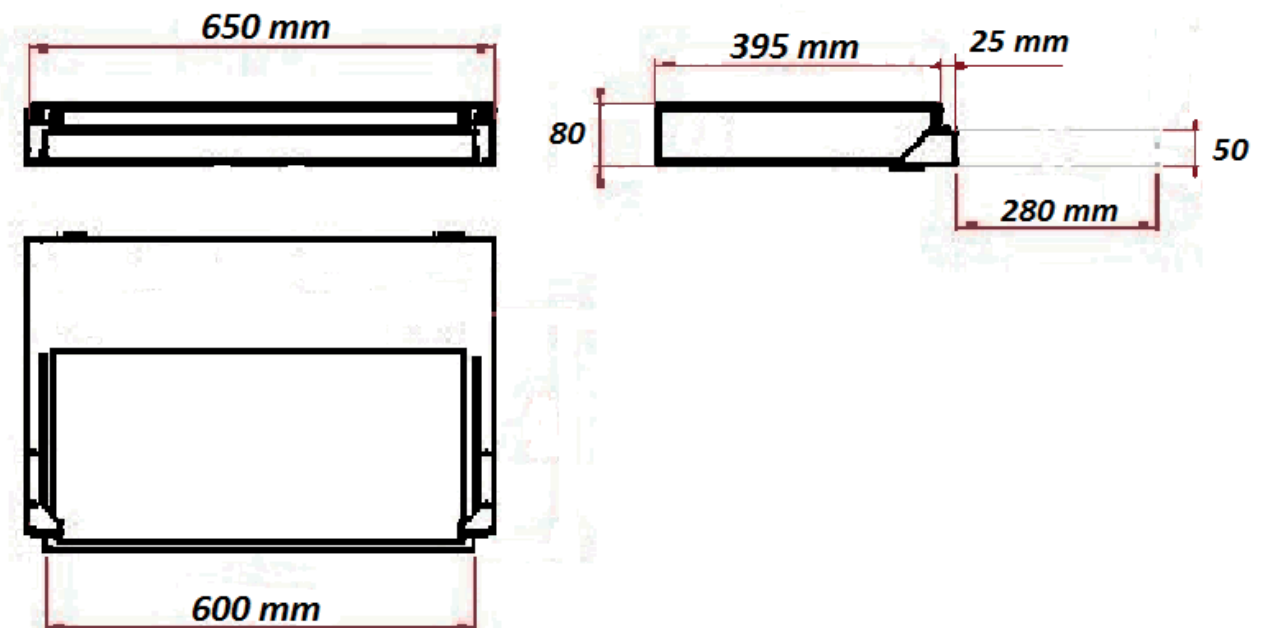



ELECTRICAL STEP

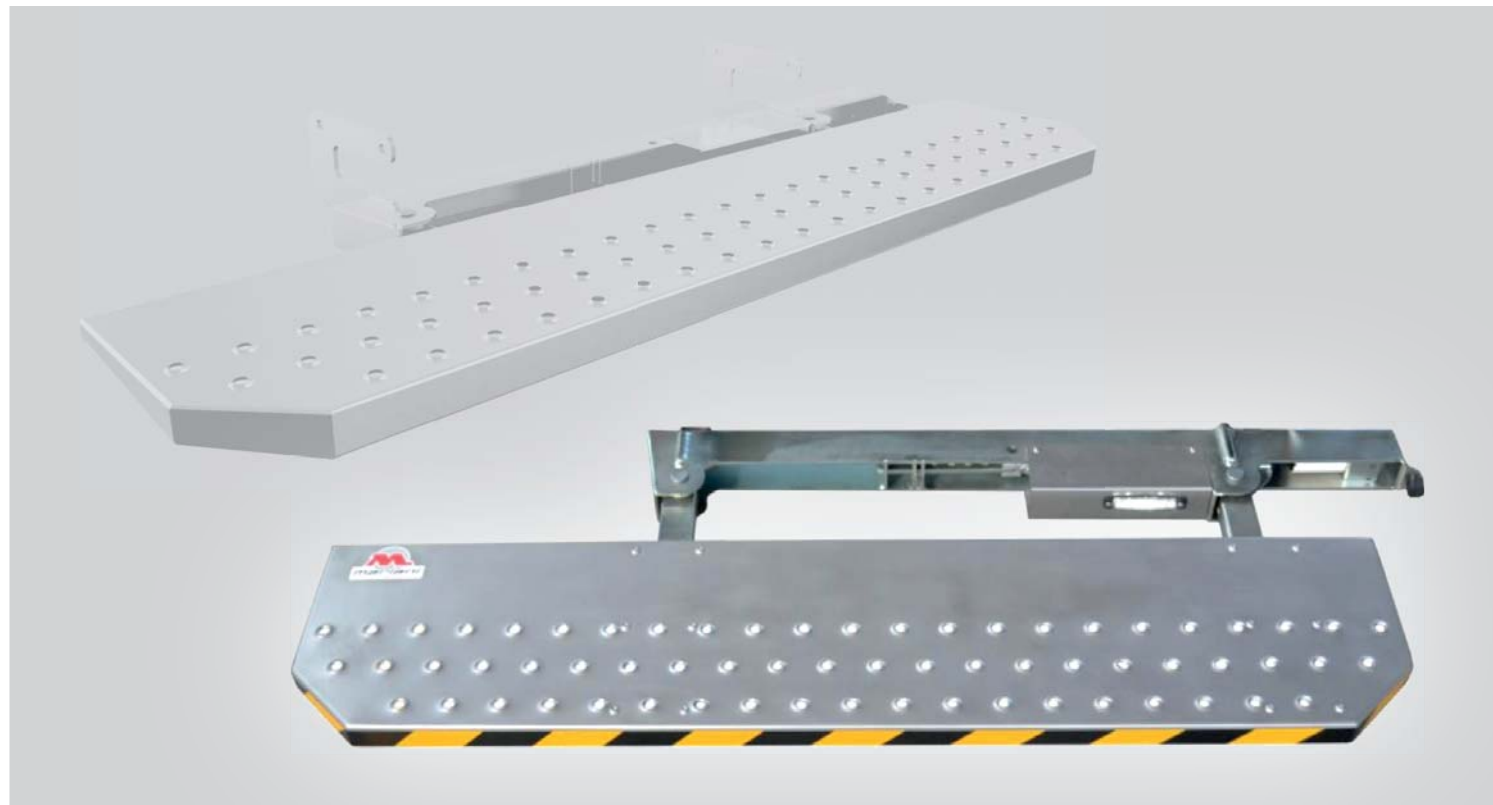

ESI 1150



TECHNICAL FEATURES

LOADING CAPACITY	300 Kg
WEIGHT	18 Kg
ELECTRICAL SYSTEM	12 V
OPENING SPEED	3 SEC
CLOSING SPEED	3 SEC

SAFETY DEVICES

The ESI 1150 electrical step helps in reducing the gap between the ground and the vehicle floor.

- Step inox.
- Zinc coated frame.
- Customized supports to adapt the steps to all types of vehicles can be available.
- Emergency lever for manual operation.
- Vehicle innerlight advising the step is out.
- Flashing light under the step when it is moving.
- Automatic stop if hitting obstacles

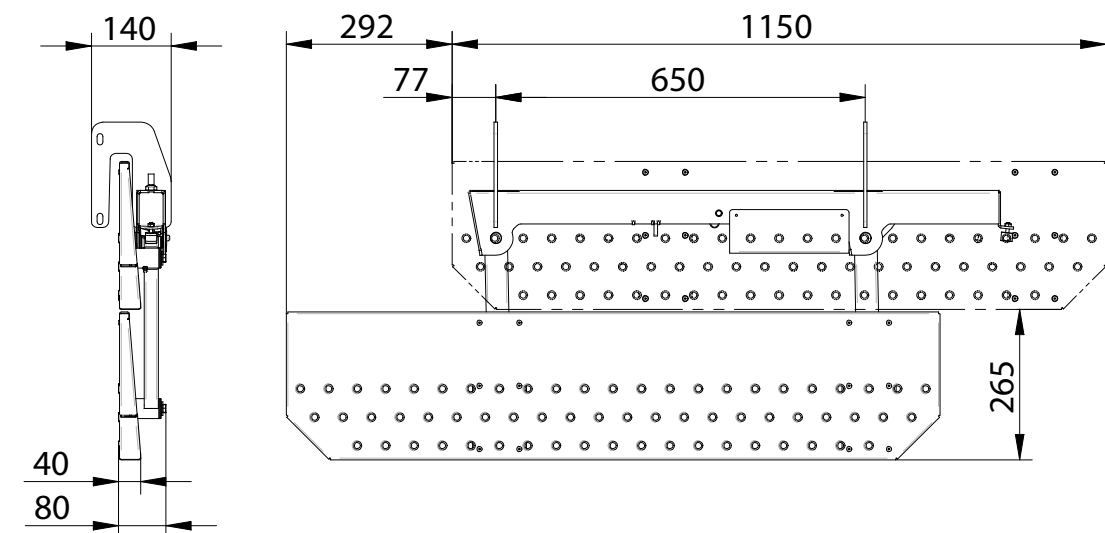



ALU-FLOOR

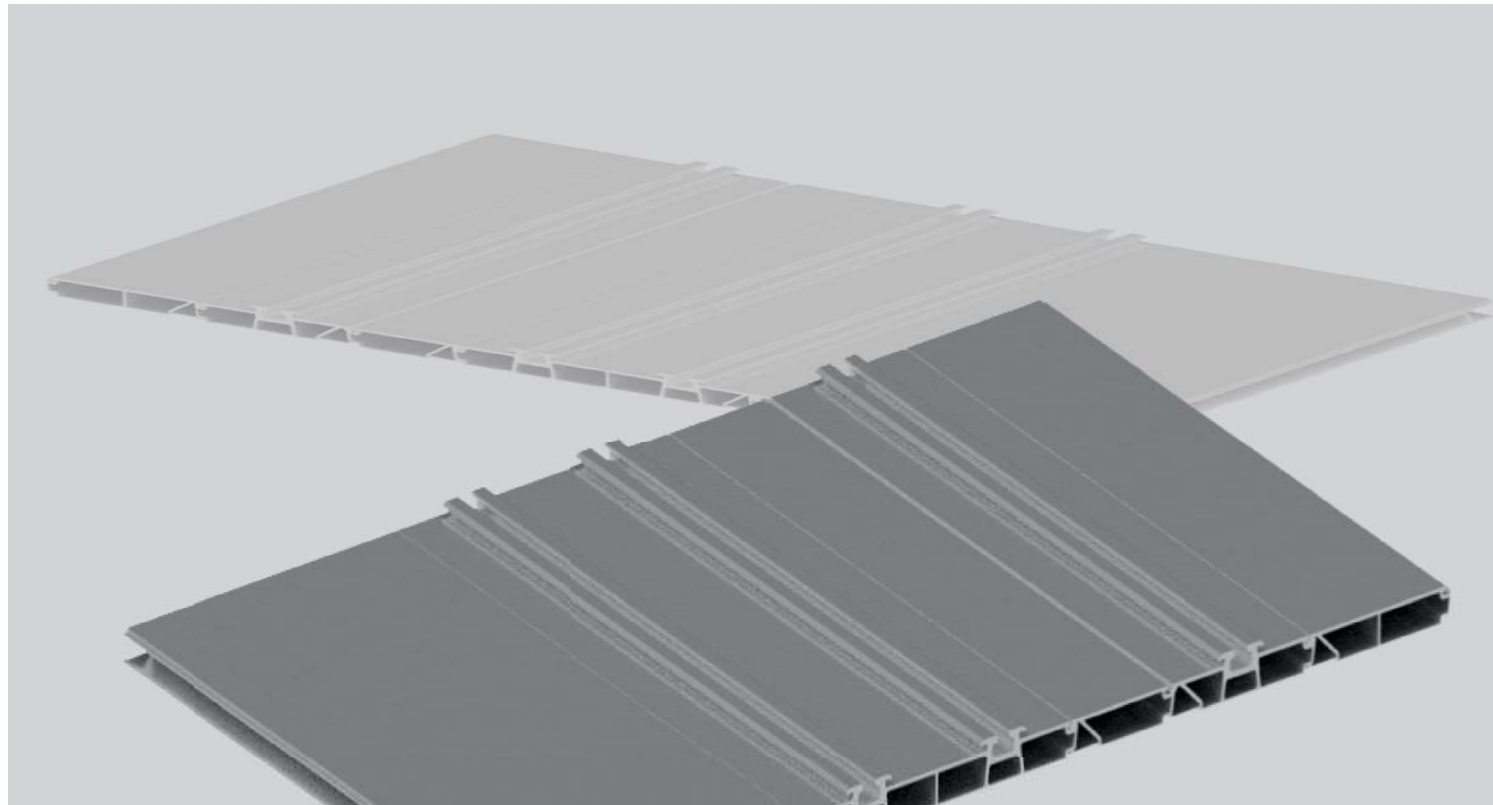

86 mm. Spacer

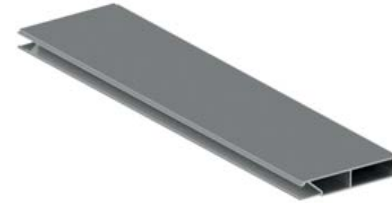

122 mm. Spacer



244 mm. Spacer

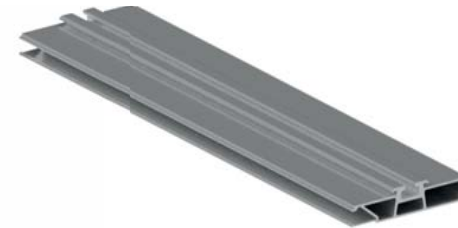

122 mm. Rail profile



244 mm. Double rail profile

DESCRIPTION

- Modular aluminium floor
- Simply click in single and double rail profiles to realize almost any vehicle floor layout
- Round drilled cut or C-profile single rail profile
- Round drilled cut or C-profile double rail profile
- Various spacer profiles
- Various lengths

TÜV tested M1, M2
ECE-R14.07



Single and Double rail profiles available
with standard $\varnothing 20 - 25,4$ holes





SICOM 2



OPTIONS

- Single seat
- Double seat
- 3 person seat bench
- Various accessories
- 4 point seat belt
- Upholstery in softline, leather etc.
- Various seat fabrics / upholstery options

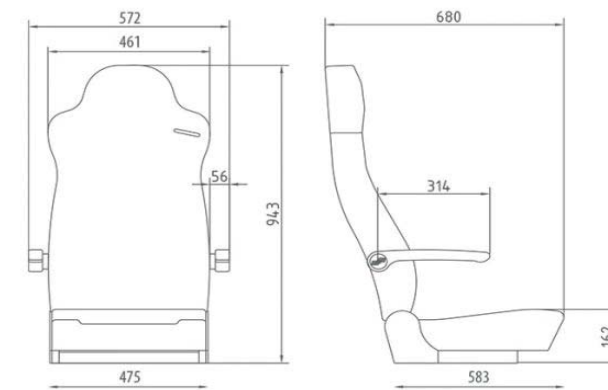

Polstervarianten:

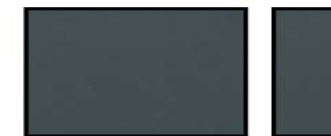

Kunstleder H07 grau



Microfieber schwarz
Kunstleder H11 schwarz

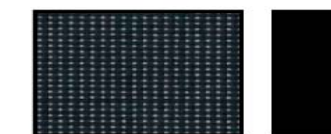

Austin
Kunstleder H11 schwarz oder

DESCRIPTION

- Rigid or adjustable backrest
- Integrated 3 point seat belt
- Integrated head rest

TÜV tested M1
ECE-R14.07

The comfortable seating system for minibuses and transporter



UPOLSTERY VARIANTS



Ford Lane blaue Streifen mit
Kunstleder H11 schwarz



MB Tunja mit
Kunstleder H11 schwarz



Austin
Kunstleder H07 grau



TAF 1



OPTIONS

- Turning device, left
- Turning device, right
- Various accessories

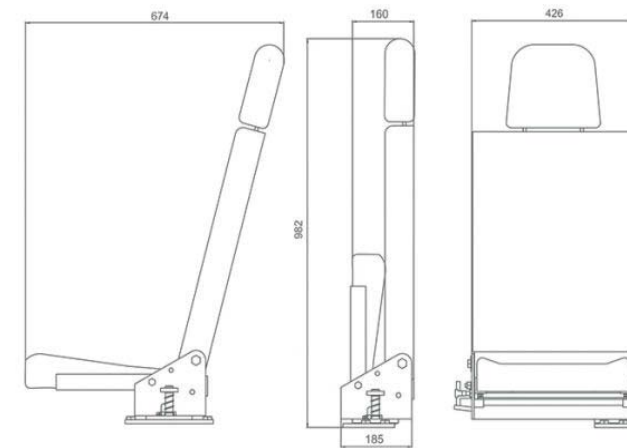

Polstervarianten:

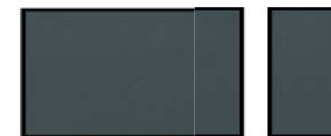

Kunstleder H07 grau



Microfieber schwarz
Kunstleder H11 schwarz



Austin
Kunstleder H11 schwarz oder

DESCRIPTION

- High rigid
- Backrest adjustable in two positions
- Integrated 3 point seat belt
- Height and angle-adjustable head rest - Asymmetrical turning device

TÜV tested M1
ECE-R14.07

The many-sided seating system for minibuses, transporters, handicapped transporters, ambulance vehicles and Patient Transport Ambulances (PTA)



UPOLSTERY VARIANTS

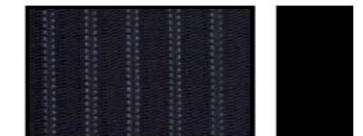

Ford Lane blaue Streifen mit
Kunstleder H11 schwarz



MB Tunja mit
Kunstleder H11 schwarz



Austin
Kunstleder H07 grau





LINEA



OPTIONS

- Grip
- Arm rest
- 4-point seat belt
- Nonstandard fabrics on additional price

THE INEXPENSIVE ALTERNATIVE

SHORT LEAD TIME

DESCRIPTION

- Rigid or adjustable backrest
- Low priced
- Easy-care
- Robust
- 3-point-seatbelt completely protected

TÜV tested M1
ECE-R14.07

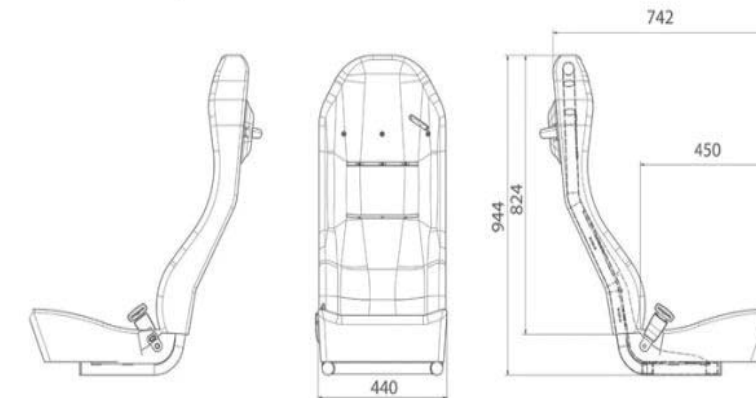

Polstervarianten:



Kunstleder H07 grau



Microfieber schwarz
Kunstleder H11 schwarz



Austin
Kunstleder H11 schwarz oder

UPOLSTERY VARIANTS



Ford Lane blaue Streifen mit
Kunstleder H11 schwarz



MB Tunja mit
Kunstleder H11 schwarz



Austin
Kunstleder H07 grau



LEG SYSTEMS



Easyleg - fast lock system



Easyleg - fast lock system with swivel



Central leg - fixed mounting



Central leg - fixed mounting with swivel



Wheel arch traversal for TAF seats



Central leg - fast lock system

DESCRIPTION

- Various heights: 300 mm, 260 mm, 190 mm
- Other heights available on request
- Passenger seating in minibuses and vans
- Emergency vehicles
- Disabled transport vehicles
- Military vehicles

TÜV tested M1
ECE-R14.07





RESTRAINTS



DESCRIPTION

- 4 retractors at the price of a standard
- 4-fold-fitting with double locking devices
- 4 retractor toothed wheels with 24 teeth
- Metal housing for retractors
- Belt locks from automotive sector large-scale series production (Honda)
- Series production with automatical sewing machines
- Height-adjustable seat belts
- Fixed lap belt connections

TÜV test certificate
in accordance with ISO 10542 and DIN 75078-2
ECE-R14.07



Standard DIN



Comfort ISO



Comfort ISO Z



Floor fixture



Quick-Connect



Quick-release



Comfort ISO with tension



Comfort ISO



Standard DIN with tension

All parts, sets and fittings can be combined according to your specific need.

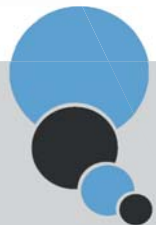



Develtex ApS
Sakskøbingvej 6
DK-7400 Herning
Tel +45 5070 9215
info@develtex.dk

